

MC-6
Multi-Channel Power
Amplifier

Introduction

Welcome to the Jeff Rowland Design Group “family” and congratulations on your purchase of what is unquestionably one of the world’s finest audio power amplifiers. **With** its combination of features such as variable multi-channel configuration, numerous function controls, interconnect possibilities, precision electronic circuitry, and accurately machined chassis components throughout, your MC-6 Multi-Channel Power Amplifier will offer you many years of musically satisfying enjoyment. Please take a few minutes to read the remainder of this Owner’s Manual before proceeding with the installation of the amplifier. A thorough understanding of the operational features will allow you to gain the maximum performance and ease of use for which this amplifier was designed. Please note that your MC-6 Multi-Channel Power Amplifier serial number begins with the letters “MC6.” This number is recorded below and is also located on the rear panel of the chassis. Please include this number with any correspondence regarding your MC-6 Multi-Channel Power Amplifier. It has been my joy to create an audio component of enduring value that reflects a higher ideal of musical and artistic expression. It is my hope that these qualities will enrich your experience of ownership.

Enjoy the music!

Jeff Rowland

President

Jeff Rowland Design Group

Jeff Rowland Design Group, Inc.

2911 North Prospect Street

Colorado Springs, CO 80907

Telephone: 719-473-1181

Fax: 719-633-4158

E-mail: jrdg@jeffrowland.com

Web: www.jeffrowland.com

Product Features

- XLR input connectors for balanced (Differential Mode™) system configuration.
- RCA input Connectors for unbalanced system configurations.
- User selectable switching between balanced and unbalanced connections.
- Automatic temperature stabilizing circuitry maintains constant operating temperature.
- DIN plug for remote turn-on and Standby operation on rear panel.
- Multi-Channel configuration for mono, stereo, three-, four-, five-, or six-channel operation.
- Stereo vertical bi- and tri-amplification capability within a single chassis.
- Linkable inputs for channel selection and input configuration.
- Automatic bias adjustment maintains optimal bias setting regardless of source signal or loudspeaker load.
- Standby power mode reduces warm-up time.
- Fail-safe operation provided by user-resettable magnetic and thermal circuit breakers located on rear panel.
- Quiet, transient-free operation during power and function mode switching.
- Automatic input muting under anomalous input or output operating conditions.
- Fully balanced Differential Mode™ circuit topology implemented from input to output.
- Low resonance, structurally integrated chassis constructed of precision-machined 6061 aircraft grade aluminum.



MC-6 Multi-Channel Power Amplifier



AC Power Cable

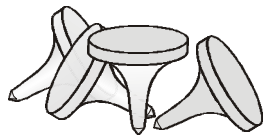

*Spiked
Coupling
Supports*



*Compliant
Isolation
Pads*



*Speaker
Terminal
Hand Wrench*

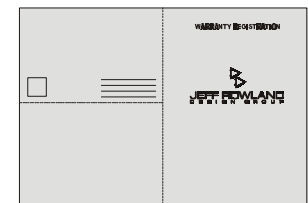

Warranty Card

Initial Inspection, Unpacking, and Contents

Initial Inspection

Inspect the shipping container for damage. If the shipping container, packing material, amplifier, or accessories are damaged or missing, notify your dealer and the shipper (if a claim is to be made) immediately. **Note:** *Many shippers require notification and inspection within twenty-four hours of delivery to determine the nature of damages incurred.*

Your MC-6 Multi-Channel Power Amplifier has undergone extensive performance evaluations, listening tests, quality control inspections, and a minimum seventy-two hour burn-in period prior to shipment and should therefore be in perfect operating condition upon receipt. If the amplifier does not operate correctly, please notify your dealer immediately.

We strongly suggest that you save all packing materials. If the amplifier is returned to your dealer or Jeff Rowland Design Group, the original packing materials must be used for shipment to avoid damage. Neither Jeff Rowland Design Group nor the shipper can be held responsible for damages incurred during transit if the original factory packing is not used. All factory returns require that Jeff Rowland Design Group issue a Return Authorization (RA) number prior to shipment.

Unpacking the Amplifier

The MC-6 is a large and heavy amplifier. Due caution should be taken when unpacking and installing the amplifier to avoid injury. The amplifier should be unpacked by at *least* two people, and there should be a portion of carpet or soft, padded cloth to stand the amplifier on when unpacking it from the shipping case.

To unpack the amplifier, stand the shipping case upright and unlock the top cover. Remove the top cover and open the gray liner bag to reveal the handles of the amplifier. Using the handles, the amplifier should be lifted straight out of the case and rested on its rear handles, standing upright. From this position, the MC-6 can be carefully and slowly lowered and set to rest on its feet and moved into its final resting place or installation point.

Contents

Ensure that all of the auxiliary components listed below are enclosed within the accessory box. Refer to the diagrams illustrated above and verify the components included.

- 1 One (1) AC Power Cable
- 2 One set of four (4) Spiked Coupling Supports
- 3 One set of four (4) Compliant Isolation Pads
- 4 One (1) Speaker Terminal Hand Wrench (7/16 inch)
- 5 One (1) Warranty Card (In some countries, warranties are provided by the respective importer.)

Amplifier Maintenance and Cleaning

Maintenance and Cleaning

All Jeff Rowland Design Group products are designed to provide a lifetime of enjoyment and listening pleasure. The chassis is sealed to prevent dust from entering and the interior of the chassis should not need cleaning during the lifetime of the product. All internal circuitry is self-adjusting such that no adjustments or maintenance of any kind are necessary over the lifetime of the product.

If the amplifier is ever in need of service, updating, or upgrading, it should only be returned to an authorized repair facility or technician for servicing.

The MC-6 Multi-Channel Power Amplifier is finely constructed from pieces of solid aluminum. The front panel of the unit is cut in a unique process that uses a diamond tipped blade. This process was refined over many years to produce an artistic and attractive finish.

Because the surface is not finished in the typical fashion of most audio and video equipment, there are a few rules that must be kept in mind when cleaning the equipment.

- Please allow the front panel to cure for 6 months before attempting to clean it. This will prevent small scratches from marring the surface before the surface coating has had a chance to harden completely.
- The top cover, sides, and bottom cover can all be cleaned with a soft cotton cloth (such as an optical lens cleaning cloth or fine furniture polishing rag) dampened with plain water. Water should be applied directly to the cloth and not the chassis. If a mark has been left on the chassis, do *not* use any type of abrasive or chemical cleaner to remove the mark. A very mild plastic or glass cleaner that does not contain ammonia should be tried only as a last resort.

Please contact the factory before trying any type of cleanser on the chassis other than water to clean the unit.

- The front panel of the unit should never be cleaned with anything other than a very soft cotton cloth and plain water or fine oil-based furniture polish. Because of the fine finish of the front panel, small scratches from the use of any other agent to clean the front panel will become very visible.

If you have any questions about the care or cleaning of your MC-6 amplifier, please contact your dealer or the Jeff Rowland Design Group factory before attempting to clean the chassis. The use of a cleanser or abrasive to clean the chassis that has not been approved by the factory will almost certainly damage the finish and will not be covered under warranty.

DC Protection System

The MC-6 Multi-Channel Power Amplifier is equipped with both magnetic and thermal circuit breakers for protection against excessive voltage input and DC signal current.

However, since no protection circuitry or system can completely protect a product from every electrical hazard, certain precautions should be observed. In the event of severe voltage hazards such as lightning, or when the amplifier will not be used for extended periods of time such as when going on holiday, the amplifier should be unplugged from the AC mains to avoid potential damage to the internal circuitry. As lightning can also be carried through other components and interconnect cables, associated electronics should also be disconnected from the AC mains, antennae, or television cable if possible.

Amplifier Front Panel



Front Panel Standby/Power Button

Amplifier Front Panel Function Control

Before attempting any system interconnection, please familiarize yourself with the front panel control of the MC-6 Multi-Channel Power Amplifier. The description below refers to the illustration above.

FRONT PANEL STANDBY/POWER BUTTON: Press this button to operate the amplifier. Press again to place the amplifier in Standby mode. This button will illuminate when the amplifier is operational. When the button is not illuminated, all amplifier inputs are muted and internal circuitry reverts to power-saving (Standby) mode. Anomalous operating conditions will place the amplifier in Standby mode and will prevent the amplifier from being switched back on again until such a condition is eliminated.

To avoid spurious noises and possible damage to the amplifier's internal circuitry, the amplifier should be switched to Standby mode when connecting or disconnecting any rear panel connections.

Note: *All ON/OFF power switching should be initiated ONLY with this button. The amplifier should not be disconnected from AC power without first placing the amplifier in Standby mode.*

Amplifier Rear Panel



2

3

1

Amplifier Rear Panel Function Controls

Before attempting any system interconnection, please familiarize yourself with the rear panel controls of the MC-6 Multi-Channel Power Amplifier. The descriptions below refer to the illustrations above.

- 1 INPUT LINK SWITCHES FOR CHANNELS 1, 2, 3, 4, 5, AND 6:** These switches allow the individual channels of the MC-6 to be linked in parallel to create single channels of great power and current capability. *THE CORRECT SWITCHES MUST BE SWITCHED ON WHEN THE APPROPRIATE JUMPERS ARE PLACED ACROSS THE CORRESPONDING OUTPUT TERMINALS.*
- 2 INPUT SELECT SWITCH FOR CHANNELS 1, 2, 3, 4, 5, AND 6:** This switch selects either the unbalanced RCA inputs or the balanced XLR inputs. This switch can be switched while the amplifier is operational and playing music. **Note:** *When the RCA position is selected, pin 2 of the XLR is shorted to pin 1 (signal ground).*
- 3 REMOTE:** A remote connector (5-Pin DIN) is provided on the rear panel for remotely switching the amplifier between operational and standby modes. The pin connections on this connector parallel the electrical contacts of the FRONT PANEL STANDBY/POWER button and lamp. Contact your dealer or the Jeff Rowland Design Group factory for further information about this feature.



WARNING: *IF ANY OUTPUT TERMINALS ARE JUMPERED TOGETHER, THE CORRESPONDING INPUTS MUST BE LINKED VIA THE INPUT LINK SWITCHES! FAILURE TO OBSERVE THIS PROCEDURE WHEN OPERATING THE AMPLIFIER WILL DAMAGE THE INTERNAL CIRCUITRY AND WILL VOID THE WARRANTY!*

BE SURE TO STRICTLY FOLLOW THE APPLICABLE CHANNEL CONFIGURATIONS AS SHOWN IN THE "SIGNAL CONNECTIONS CONTENTS DIRECTORY" ON PAGE 14 OF THIS MANUAL.

Amplifier Rear Panel

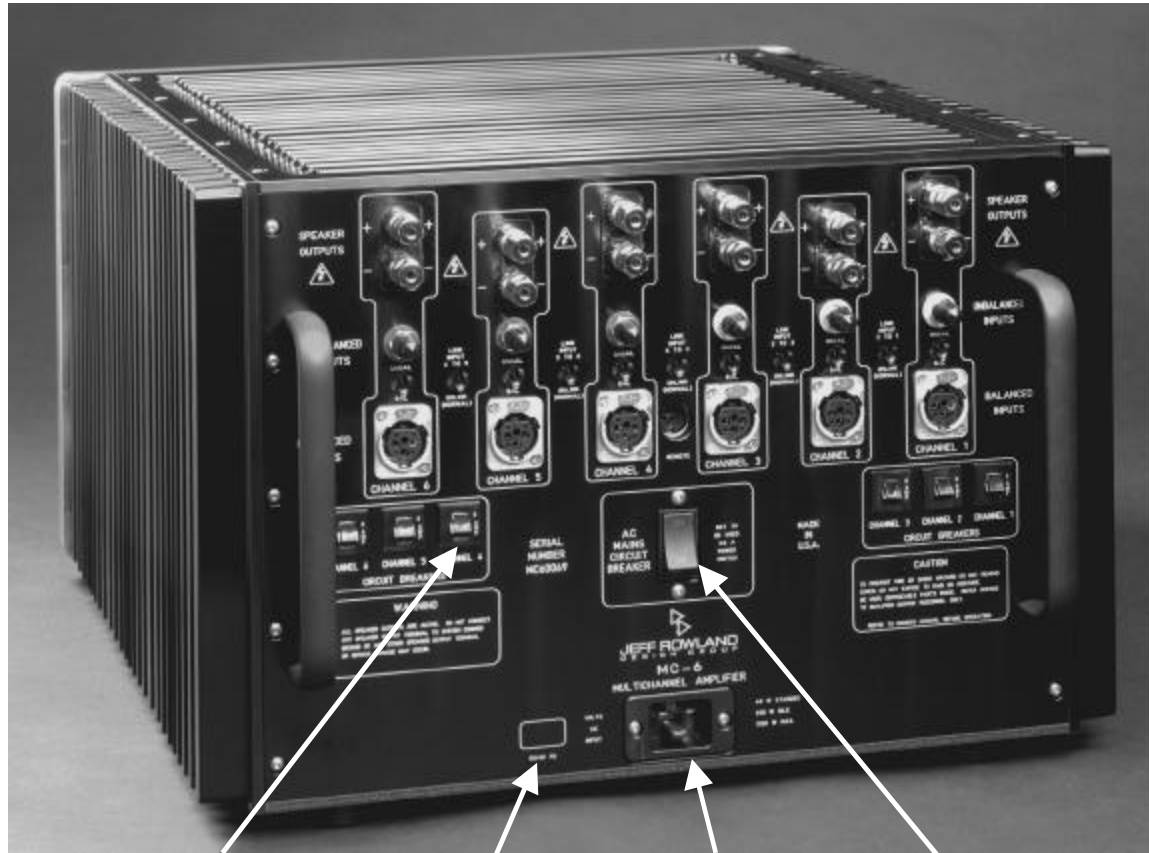

4

1

3

2

Installation

Locate the amplifier as close as possible to its final installation point. Allow access to the rear panel for making connections.

The MC-6 Multi-Channel Power Amplifier is convection cooled, eliminating the need for fan or forced-air cooling. When operating, the chassis should have at least two (2) inches of air space around the heatsink areas. Multiple chassis can be stacked vertically, facilitating an upward flow of warm air currents throughout the vertical heatsink areas. This upward flow must not be blocked or recirculated around the chassis if proper cooling is to be maintained.

Typical installations allow the amplifier to be rigidly coupled to a support structure or floor via the included spiked coupling supports. In carpeted installations, these supports provide excellent anchoring from the amplifier chassis to the rigid floor or sub-floor below. If there is concern about damage to the structure or floor's finish, a coin can be placed beneath each spiked coupling support. In installations where the resonant properties of the supporting structure are poor, the amplifier chassis can be loosely coupled to the supporting structure via the compliant isolation interface pads. This will help to attenuate the transfer of vibration or resonant energy from the support structure to the amplifier chassis.

Rear Panel Power Connections

Important: Please strictly follow the steps in order as outlined below before operating your MC-6 Multi-Channel Power Amplifier.

- 1 Verify that the VOLTS AC input identified on the rear panel near the AC input socket is the same as the AC mains voltage in your area. If the voltage does not match, do *not* connect the amplifier to AC power and contact your dealer immediately.
- 2 Verify that the AC MAINS CIRCUIT BREAKER is closed (green color visible).
- 3 Install the AC Power Cable between the amplifier and your AC mains outlet.
- 4 Verify that the circuit breakers for channels 1, 2, 3, 4, 5, and 6 are closed (no white area visible on each breaker).

Note: *If the amplifier is to be moved to another location, always place the unit in Standby mode before disconnecting the AC power cable from the AC mains wall outlet.*

Never use the AC mains circuit breaker as a power switch to connect or disconnect the amplifier from AC mains power.

Use, Care, and Signal Connections

The Jeff Rowland Design Group MC-6 Power Amplifier has been designed with numerous protection circuits and to be able to operate at the highest level of performance in any normal operating situation. However, there are a few important use and care principles that must be kept in mind when operating the amplifier.

- Do not expose the amplifier to rain, moisture, or excessively damp conditions.
- Do not disconnect the amplifier from AC mains without first placing the amplifier in Standby mode.
- The MC-6 Multi-Channel Power Amplifier must not be modified in any way, other than according to official service bulletins from Jeff Rowland Design Group. Otherwise, the factory warranty will be immediately voided.
- The MC-6 Multi-Channel Power Amplifier can be operated at a nominal 100, 115, 200, or 230 volts AC. For this reason, you should first assure that the amplifier has been wired for the correct AC input voltage before operation.
- As the MC-6 generates a significant amount of heat, it should not be placed in a cabinet or area where the heatsinks are not able to properly dissipate heat during operation. Please make sure adequate ventilation is provided.
- To clean the MC-6 Multi-Channel Power Amplifier, use a soft cloth moistened with plain water. Never apply water, dusting sprays, solvents, abrasives, or cleaning fluids directly to the chassis!
- When operating the MC-6, a properly grounded AC receptacle should be used. A potential shock hazard may result if the supplied 3-wire, grounded AC cord set ground terminal is defeated or lifted or the unit is connected to a 2-wire ungrounded AC outlet.

Signal Connections

The MC-6 Multi-Channel Power Amplifier offers unprecedented channel configuration capability and compatibility with associated audio components. When connecting or disconnecting speaker or interconnect cables, it is always necessary to place the amplifier in Standby mode (FRONT PANEL STANDBY/POWER BUTTON not illuminated or OFF).

Complete instructions for configuring and connecting the amplifier can be found in the next portion of this manual.

Please also note that any changes or updates to the manual will be posted on the Jeff Rowland Design Group web site at <http://www.jeffrowland.com>.



Warning: *Both positive and negative outputs are electrically active with respect to chassis and/or system ground potential! Therefore, this amplifier cannot be used in certain loudspeaker switching configurations, such as those used in retail demonstrations. Failure to avoid these precautions can result in damage to the amplifier and will void the warranty.*

Signal Connections Contents Directory

The Jeff Rowland Design Group MC-6 Multi-Channel Power Amplifier features an innovative multi-channel adjustment topology that allows the amplifier to be configured for mono, stereo, three-, four-, five-, or even 6-channel operation. This flexibility means monoblock, two-channel stereo, bi-amplification, tri-amplification, and a number of home theater applications can be realized within a single amplifier chassis with a few easy adjustments. Within the amplifier there are two high-current amplifier sections and four standard amplifier sections. These amplifier sections can be linked to each other to configure the amplifier for different applications. The configuration procedure for the MC-6 Multi-Channel Amplifier is a quick and simple procedure, able to be performed within minutes with no additional tools or disassembly required.

For certain configurations, the outputs of multiple channels must be linked using short sections of Output Terminal Linking Cable. Linking Cables manufactured specifically for the MC-6 are available from Jeff Rowland Design group or can be made from the same basic materials as your selected loudspeaker cables. Please have your loudspeaker cable manufacturer contact the Jeff Rowland Design Group factory for proper instruction in the construction of these linking cables.

Technical Note: Linking (paralleling) multiple channels together is not similar to “bridging” and is an exclusive feature due to the unique circuitry of the MC-6. Linking channels together increases the maximum current available and decreases the electrical load of each linked channel. This yields improved electrical and sonic performance, especially under demanding conditions. For example, if channels 1 through 6 are linked together, the result is a single channel with a maximum output current capability equal to the sum of the current capability of channels 1 through 6. When linking channels, performance of the amplifier actually increases as a greater number of channels are linked together.

Input and Output Connections

Single Channel Monoblock Use	Page 15
Two-Channel, High Current Stereo Use	Page 17
Two-Channel, Vertical Bi-Amplification Use	Page 19
Two-Channel, Vertical Tri-Amplification Use	Page 21
Three-Channel Audio/Video Use	Page 23
Four-Channel, High Current Audio/Video Use	Page 25
Five-Channel Audio/Video Use	Page 27
Six-Channel Audio/Video Use	Page 29

Diagram for Single-Channel Monoblock Configuration

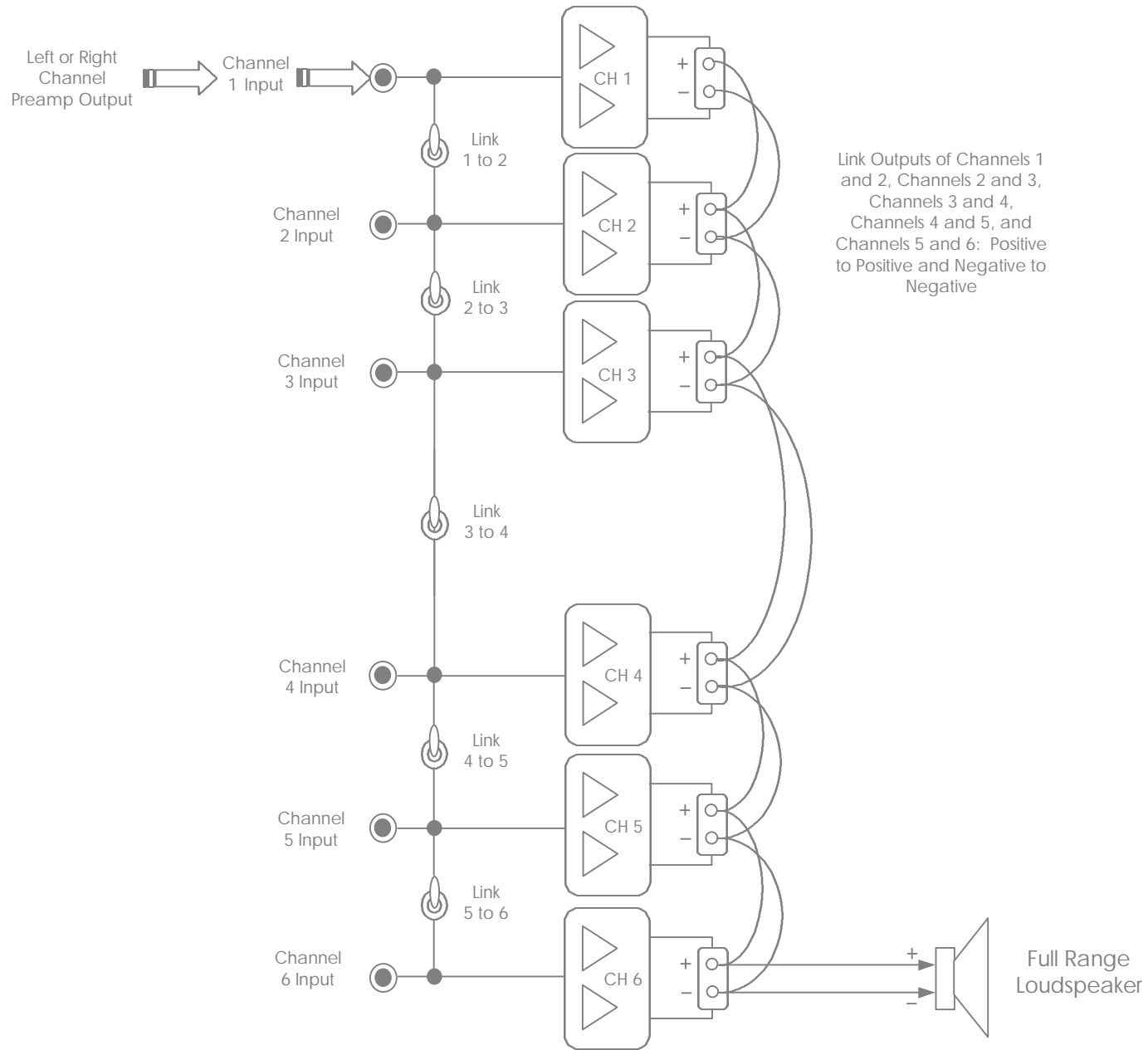

To Configure the Amplifier for Single-Channel Monoblock Use

- 1 Connect the left or right channel interconnect from your pre-amp or source component (depending on which channel of operation the amplifier is to be used for) to the CHANNEL 1 balanced XLR or unbalanced RCA input connector. Select the correct balanced or unbalanced input connector by flipping the Channel 1 BAL/UNBAL switch towards the connector that is being used.
- 2 Flip the LINK INPUT 2 TO 1/UNLINK (NORMAL) switch "ON", or up towards LINK INPUT 2 TO 1. Flip the LINK INPUT 3 TO 2/UNLINK (NORMAL) switch "ON", or up towards LINK INPUT 3 TO 2. Flip the LINK INPUT 4 TO 3/UNLINK (NORMAL) switch "ON", or up towards LINK INPUT 4 TO 3. Flip the LINK INPUT 5 TO 4/UNLINK (NORMAL) switch "ON", or up towards LINK INPUT 5 TO 4. Flip the LINK INPUT 6 TO 5/UNLINK (NORMAL) switch "ON", or up towards LINK INPUT 6 TO 5.
- 3 Using the output terminal linking cables of your choice (see page 14), connect the output binding posts of CHANNEL 1 to CHANNEL 2, CHANNEL 2 to CHANNEL 3, CHANNEL 3 to CHANNEL 4, CHANNEL 4 to CHANNEL 5, and CHANNEL 5 to CHANNEL 6.
- 4 Connect the corresponding left or right loudspeaker cable to the Channel 6 SPEAKER OUTPUT connector.

The signal connections are now complete. Please recheck your connections before operating the amplifier.

Diagram for Two-Channel Stereo, High Current Configuration

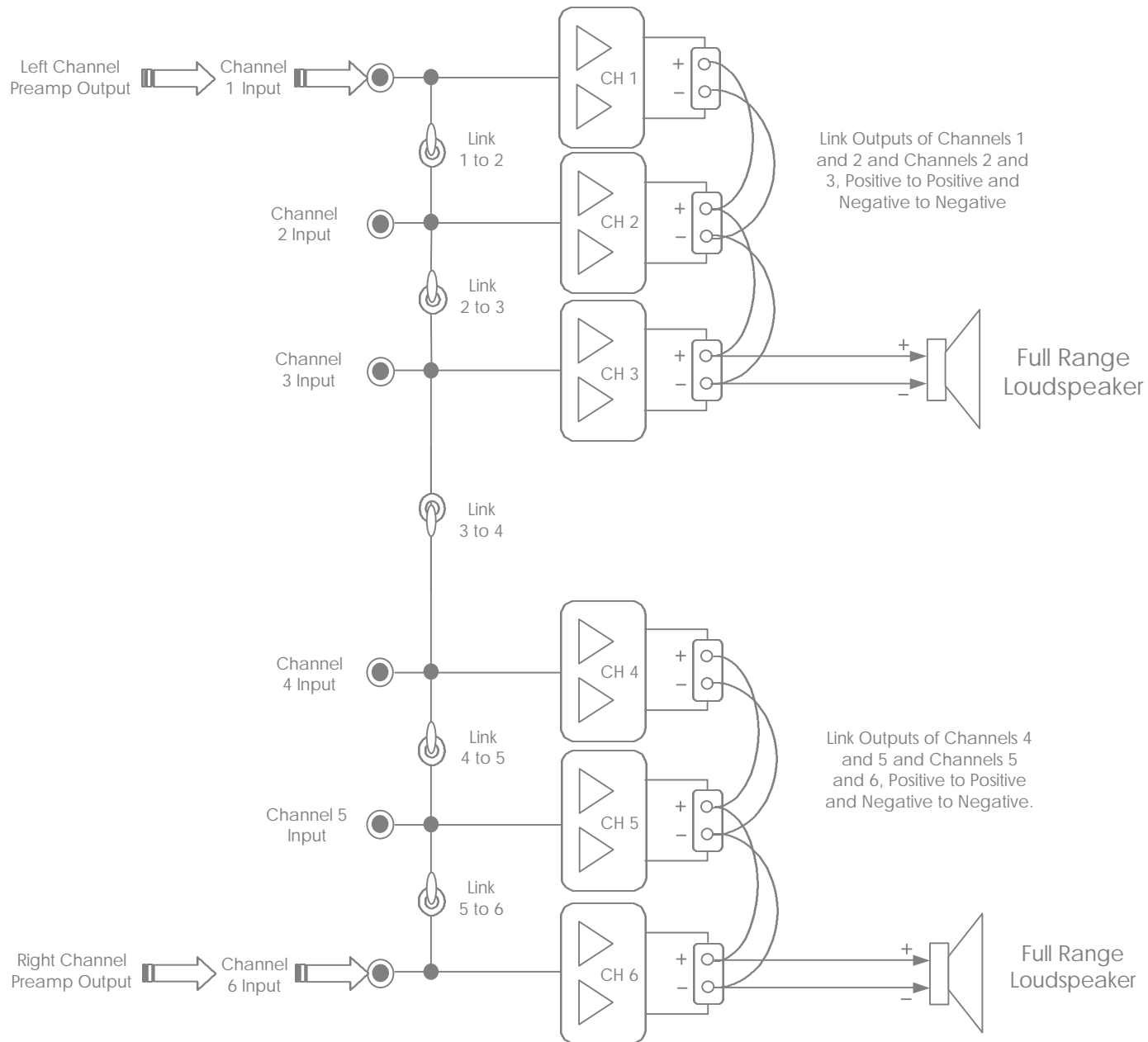

To Configure the Amplifier for Two-Channel Stereo, High Current Use

- 1 Connect the left channel interconnect from your pre-amp or source component to the CHANNEL 1 balanced XLR or unbalanced RCA input connector. Select the correct balanced or unbalanced input connector by flipping the Channel 1 BAL/UNBAL switch towards the connector that is being used.
- 2 Connect the right channel interconnect from your pre-amp or source component to the CHANNEL 6 balanced XLR or unbalanced RCA input connector. Select the correct balanced or unbalanced input connector by flipping the Channel 6 BAL/UNBAL switch towards the connector that is being used.
- 3 Flip the LINK INPUT 2 TO 1/UNLINK (NORMAL) switch "ON", or up towards LINK INPUT 2 TO 1. Flip the LINK INPUT 3 TO 2/UNLINK (NORMAL) switch "ON", or up towards LINK INPUT 3 TO 2. Flip the LINK INPUT 6 TO 5/UNLINK (NORMAL) switch "ON", or up towards LINK INPUT 6 TO 5. Flip the LINK INPUT 5 TO 4/UNLINK (NORMAL) switch "ON", or up towards LINK INPUT 5 TO 4.
- 4 Using the output terminal linking cables of your choice (see page 14), connect the output binding posts of CHANNEL 1 to CHANNEL 2 and CHANNEL 2 to CHANNEL 3.
- 5 Using the output terminal linking cables of your choice (see page 14), connect the output binding posts of CHANNEL 6 to CHANNEL 5 and CHANNEL 5 to CHANNEL 4.
- 6 Connect your left loudspeaker cable to the Channel 1 SPEAKER OUTPUT connector.
- 7 Connect your right loudspeaker cable to the Channel 6 SPEAKER OUTPUT connector.

The signal connections are now complete. Please recheck your connections before operating the amplifier.

Diagram for Two-Channel Stereo, Vertical Bi-Amplification Use

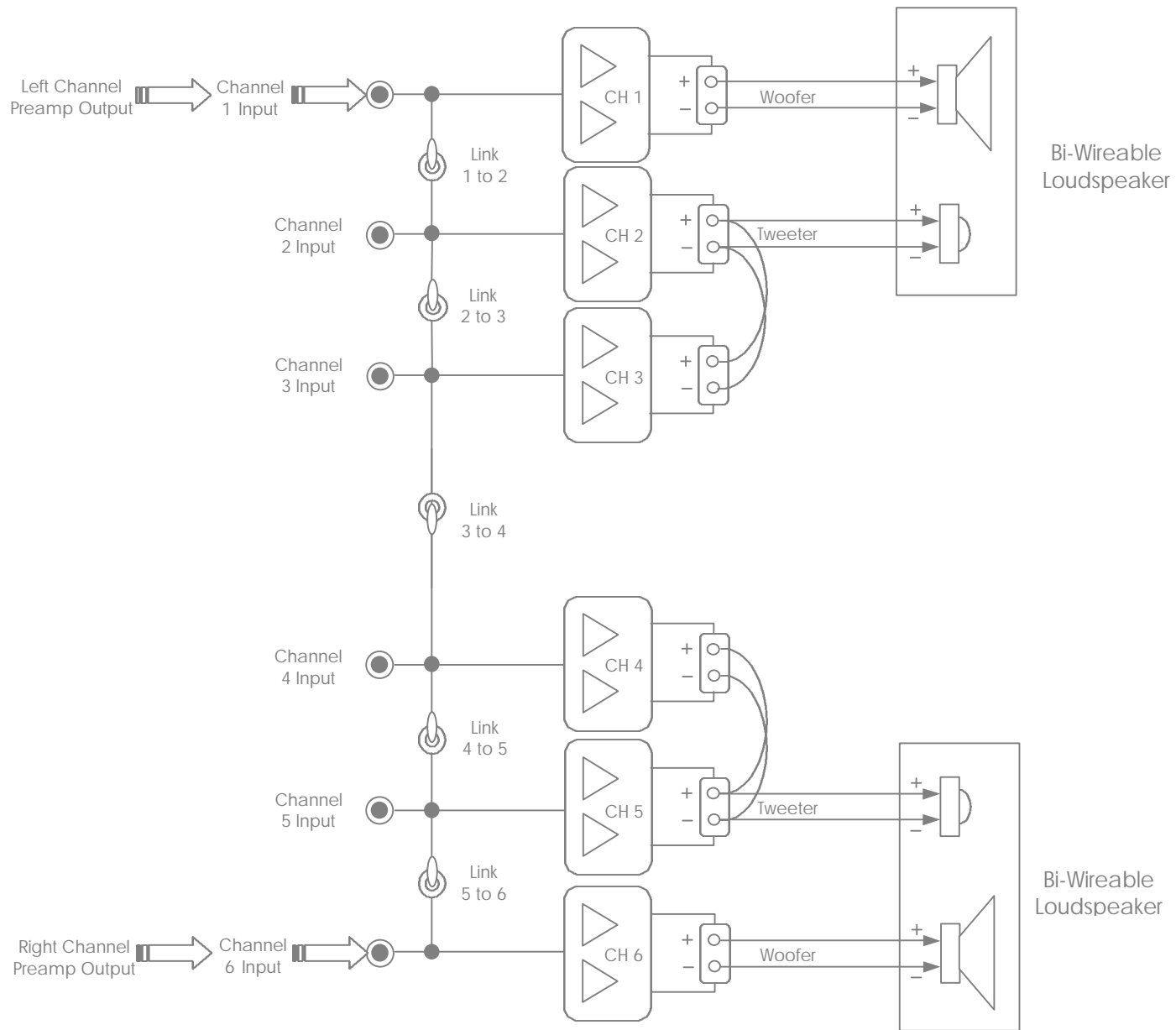

To Configure the Amplifier for Two-Channel Stereo, Vertical Bi-Amplification Use

- 1 Connect the left channel interconnect from your pre-amp or source component to the CHANNEL 1 balanced XLR or unbalanced RCA input connector. Select the correct balanced or unbalanced input connector by flipping the Channel 1 BAL/UNBAL switch towards the connector that is being used.
- 2 Connect the right channel interconnect from your pre-amp or source component to the CHANNEL 6 balanced XLR or unbalanced RCA input connector. Select the correct balanced or unbalanced input connector by flipping the Channel 6 BAL/UNBAL switch towards the connector that is being used.
- 3 Flip the LINK INPUT 2 TO 1/UNLINK (NORMAL) switch "ON", or up towards LINK INPUT 2 TO 1. Flip the LINK INPUT 3 TO 2/UNLINK (NORMAL) switch "ON", or up towards LINK INPUT 3 TO 2. Flip the LINK INPUT 6 TO 5/UNLINK (NORMAL) switch "ON", or up towards LINK INPUT 6 TO 5. Flip the LINK INPUT 5 TO 4/UNLINK (NORMAL) switch "ON", or up towards LINK INPUT 5 TO 4.
- 4 Using the output terminal linking cables of your choice (see page 14), connect the output binding posts of CHANNEL 3 to CHANNEL 2.
- 5 Using the output terminal linking cables of your choice (see page 14), connect the output binding posts of CHANNEL 5 to CHANNEL 4.
- 6 Connect your left woofer loudspeaker cable to the Channel 1 SPEAKER OUTPUT connector. Connect your left tweeter loudspeaker cable to the Channel 2 SPEAKER OUTPUT connector.
- 7 Connect your right tweeter loudspeaker cable to the Channel 5 SPEAKER OUTPUT connectors. Connect your right woofer loudspeaker cable to the Channel 6 SPEAKER OUTPUT connector.

The signal connections are now complete. Please recheck your connections before operating the amplifier.

Diagram for Two-Channel Stereo, Vertical Tri-Amplification Configuration

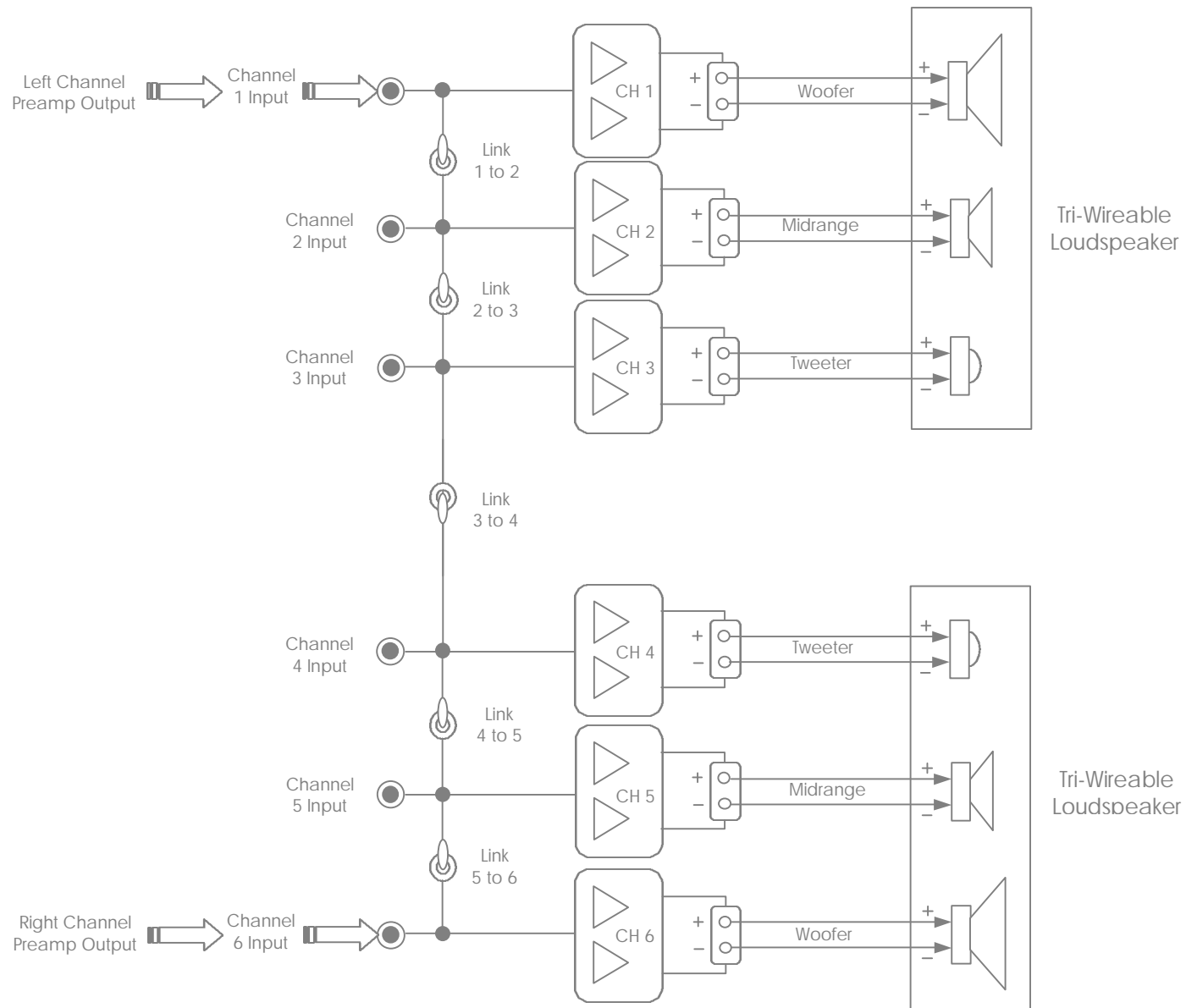

To Configure the Amplifier for Two-Channel Stereo, Vertical Tri-Amplification Use

- 1 Connect the left channel interconnect from your pre-amp or source component to the CHANNEL 1 balanced XLR or unbalanced RCA input connector. Select the correct balanced or unbalanced input connector by flipping the Channel 1 BAL/UNBAL switch towards the connector that is being used.
- 2 Connect the right channel interconnect from your pre-amp or source component to the CHANNEL 6 balanced XLR or unbalanced RCA input connector. Select the correct balanced or unbalanced input connector by flipping the Channel 6 BAL/UNBAL switch towards the connector that is being used.
- 3 Flip the LINK INPUT 2 TO 1/UNLINK (NORMAL) switch "ON", or up towards LINK INPUT 2 TO 1. Flip the LINK INPUT 3 TO 2/UNLINK (NORMAL) switch "ON", or up towards LINK INPUT 3 TO 2.
- 4 Flip the LINK INPUT 6 TO 5/UNLINK (NORMAL) switch "ON", or up towards LINK INPUT 6 TO 5. Flip the LINK INPUT 5 TO 4/UNLINK (NORMAL) switch "ON", or up towards LINK INPUT 5 TO 4.
- 5 Connect your left woofer loudspeaker cable to the Channel 1 SPEAKER OUTPUT connector. Connect your left midrange loudspeaker cable to the Channel 2 SPEAKER OUTPUT connector. Connect your left tweeter loudspeaker cable to the Channel 3 SPEAKER OUTPUT connector.
- 6 Connect your right woofer loudspeaker cable to the Channel 6 SPEAKER OUTPUT connector. Connect your right midrange loudspeaker cable to the Channel 5 SPEAKER OUTPUT connector. Connect your right tweeter loudspeaker cable to the Channel 4 SPEAKER OUTPUT connector.

The signal connections are now complete. Please recheck your connections before operating the amplifier.

Diagram for Three-Channel Configuration

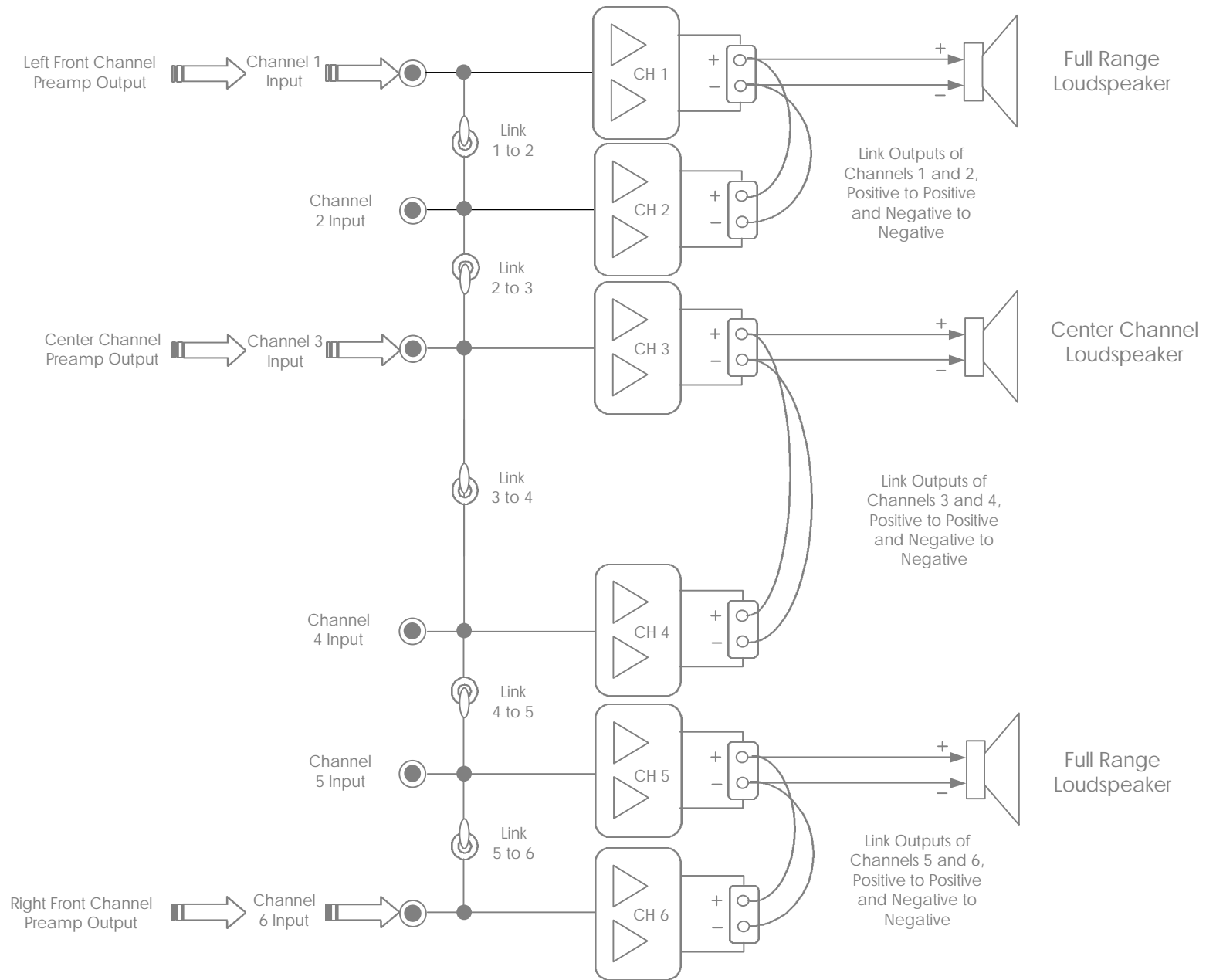

To Configure the Amplifier for Three Channel Use

- 1 Connect the left front channel interconnect from your pre-amp or source component to the CHANNEL 1 balanced XLR or unbalanced RCA input connector. Select the correct balanced or unbalanced input connector by flipping the Channel 1 BAL/UNBAL switch towards the connector that is being used.
- 2 Connect the right front channel interconnect from your pre-amp or source component to the CHANNEL 6 balanced XLR or unbalanced RCA input connector. Select the correct balanced or unbalanced input connector by flipping the Channel 6 BAL/UNBAL switch towards the connector that is being used.
- 3 Connect the center channel interconnect from your pre-amp or source component to the CHANNEL 3 balanced XLR or unbalanced RCA input connector. Select the correct balanced or unbalanced input connector by flipping the Channel 3 BAL/UNBAL switch towards the connector that is being used.
- 4 Flip the LINK INPUT 6 TO 5/UNLINK (NORMAL) switch "ON", or up towards LINK INPUT 6 TO 5. Flip the LINK INPUT 4 TO 3/UNLINK (NORMAL) switch "ON", or up towards LINK INPUT 4 TO 3. Flip the LINK INPUT 2 TO 1/UNLINK (NORMAL) switch "ON", or up towards LINK INPUT 2 TO 1.
- 5 Using the output terminal linking cables of your choice (see page 14), connect the output binding posts of CHANNEL 1 to CHANNEL 2.
- 6 Using the output terminal linking cables of your choice (see page 14), connect the output binding posts of CHANNEL 3 to CHANNEL 4.
- 7 Using the output terminal linking cables of your choice (see page 14), connect the output binding posts of CHANNEL 5 to CHANNEL 6.
- 8 Connect your left front loudspeaker cable to the Channel 1 SPEAKER OUTPUT connector.
- 9 Connect your right front loudspeaker cable to the Channel 5 SPEAKER OUTPUT connector.
- 10 Connect your center channel loudspeaker cable to the Channel 3 SPEAKER OUTPUT connector.

The signal connections are now complete. Please recheck your connections before operating the amplifier.

Diagram for Four-Channel Configuration

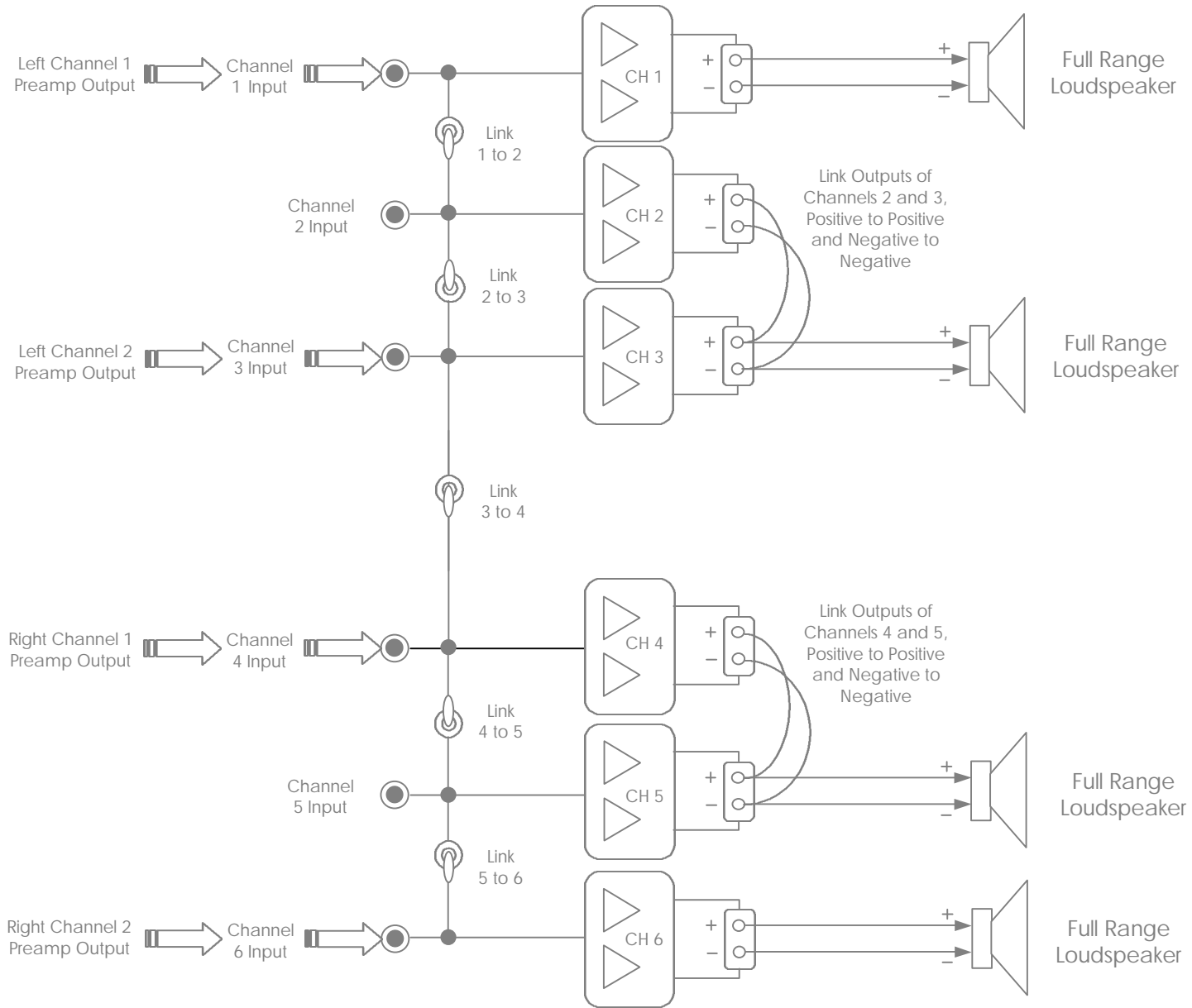

To Configure the Amplifier for Four-Channel Use

- 1 Connect the left channel 1 interconnect from your pre-amp or source component to the CHANNEL 1 balanced XLR or unbalanced RCA input connector. Select the correct balanced or unbalanced input connector by flipping the Channel 1 BAL/UNBAL switch towards the connector that is being used.
- 2 Connect the right channel 1 interconnect from your pre-amp or source component to the CHANNEL 4 balanced XLR or unbalanced RCA input connector. Select the correct balanced or unbalanced input connector by flipping the Channel 4 BAL/UNBAL switch towards the connector that is being used.
- 3 Connect the left channel 2 interconnect from your pre-amp or source component to the CHANNEL 3 balanced XLR or unbalanced RCA input connector. Select the correct balanced or unbalanced input connector by flipping the Channel 3 BAL/UNBAL switch towards the connector that is being used.
- 4 Connect the right channel 2 interconnect from your pre-amp or source component to the CHANNEL 6 balanced XLR or unbalanced RCA input connector. Select the correct balanced or unbalanced input connector by flipping the Channel 6 BAL/UNBAL switch towards the connector that is being used.
- 5 Flip the LINK INPUT 5 TO 4/UNLINK (NORMAL) switch "ON", or up towards LINK INPUT 5 TO 4. Flip the LINK INPUT 3 TO 2/UNLINK (NORMAL) switch "ON", or up towards LINK INPUT 3 TO 2.
- 6 Using the output terminal linking cables of your choice (see page 14), connect the output binding posts of CHANNEL 2 to CHANNEL 3.
- 7 Using the output terminal linking cables of your choice (see page 14), connect the output binding posts of CHANNEL 4 to CHANNEL 5.
- 8 Connect your left channel 1 loudspeaker cable to the Channel 1 SPEAKER OUTPUT connector.
- 9 Connect your right channel 1 loudspeaker cable to the Channel 5 SPEAKER OUTPUT connector.
- 10 Connect your left channel 2 loudspeaker cable to the Channel 3 SPEAKER OUTPUT connector.
- 11 Connect your right channel 2 loudspeaker cable to the Channel 6 SPEAKER OUTPUT connector.

The signal connections are now complete. Please recheck your connections before operating the amplifier.

Diagram for Five-Channel Configuration

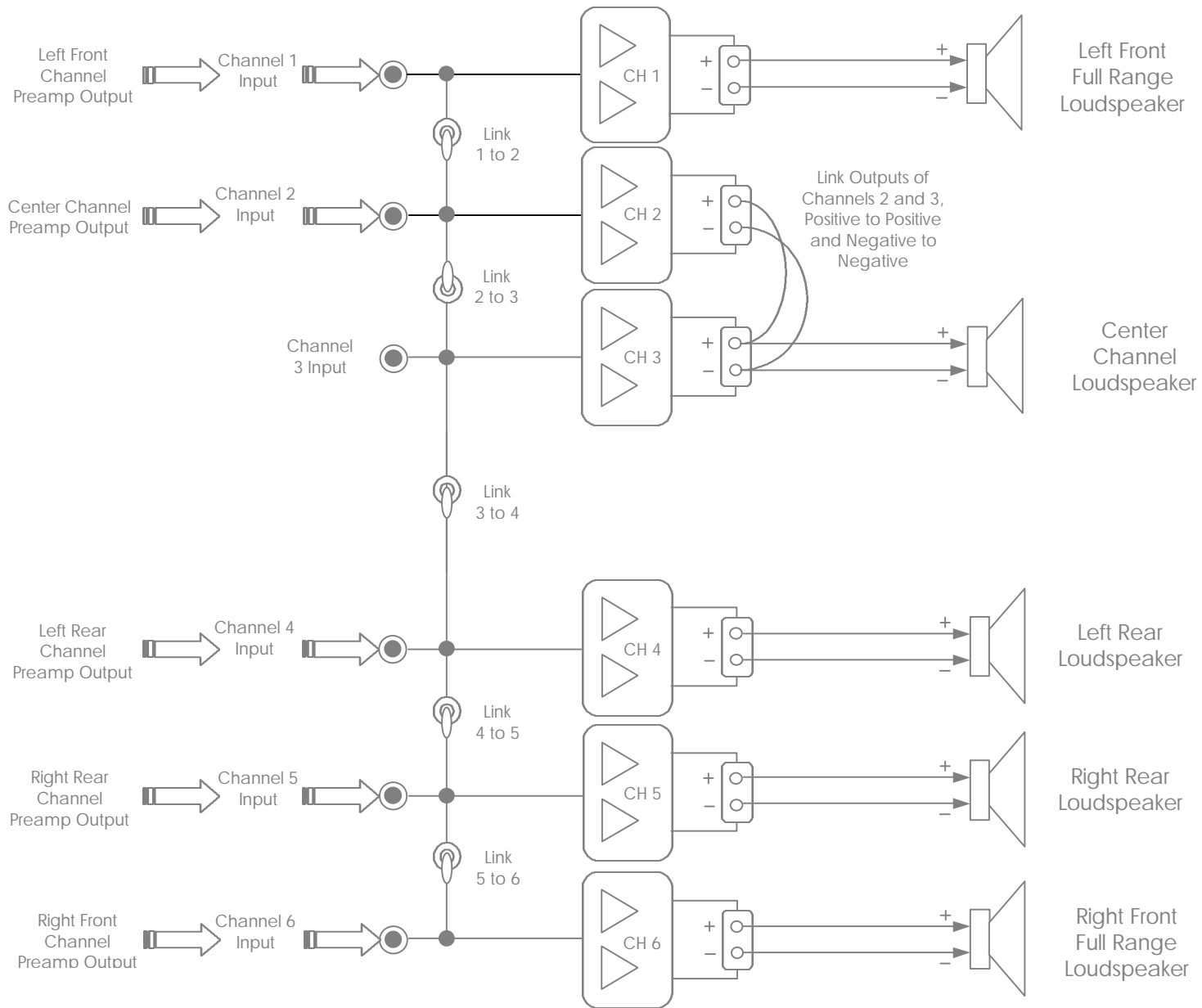

To Configure the Amplifier for Five-Channel Use

- 1 Connect the left front channel interconnect from your pre-amp or source component to the CHANNEL 1 balanced XLR or unbalanced RCA input connector. Select the correct balanced or unbalanced input connector by flipping the Channel 1 BAL/UNBAL switch towards the connector that is being used.
- 2 Connect the center channel interconnect from your pre-amp or source component to the CHANNEL 2 balanced XLR or unbalanced RCA input connector. Select the correct balanced or unbalanced input connector by flipping the Channel 2 BAL/UNBAL switch towards the connector that is being used.
- 3 Connect the left rear channel interconnect from your pre-amp or source component to the CHANNEL 4 balanced XLR or unbalanced RCA input connector. Select the correct balanced or unbalanced input connector by flipping the Channel 4 BAL/UNBAL switch towards the connector that is being used.
- 4 Connect the right rear channel interconnect from your pre-amp or source component to the CHANNEL 5 balanced XLR or unbalanced RCA input connector. Select the correct balanced or unbalanced input connector by flipping the Channel 5 BAL/UNBAL switch towards the connector that is being used.
- 5 Connect the right front channel interconnect from your pre-amp or source component to the CHANNEL 6 balanced XLR or unbalanced RCA input connector. Select the correct balanced or unbalanced input connector by flipping the Channel 6 BAL/UNBAL switch towards the connector that is being used.
- 6 Flip the LINK INPUT 3 TO 2/UNLINK (NORMAL) switch "ON", or up towards LINK INPUT 3 TO 2.
- 7 Using the output terminal linking cables of your choice (see page 14), connect the output binding posts of CHANNEL 2 to CHANNEL 3.
- 8 Connect your left front loudspeaker cable to the Channel 1 SPEAKER OUTPUT connector.
- 9 Connect your center channel loudspeaker cable to the Channel 3 SPEAKER OUTPUT connector.
- 10 Connect your left rear loudspeaker cable to the Channel 4 SPEAKER OUTPUT connector.
- 11 Connect your right rear loudspeaker cable to the Channel 5 SPEAKER OUTPUT connector.
- 12 Connect your right front loudspeaker cable to the Channel 6 SPEAKER OUTPUT connector.

The signal connections are now complete. Please recheck your connections before operating the amplifier.

Diagram for Six-Channel Configuration

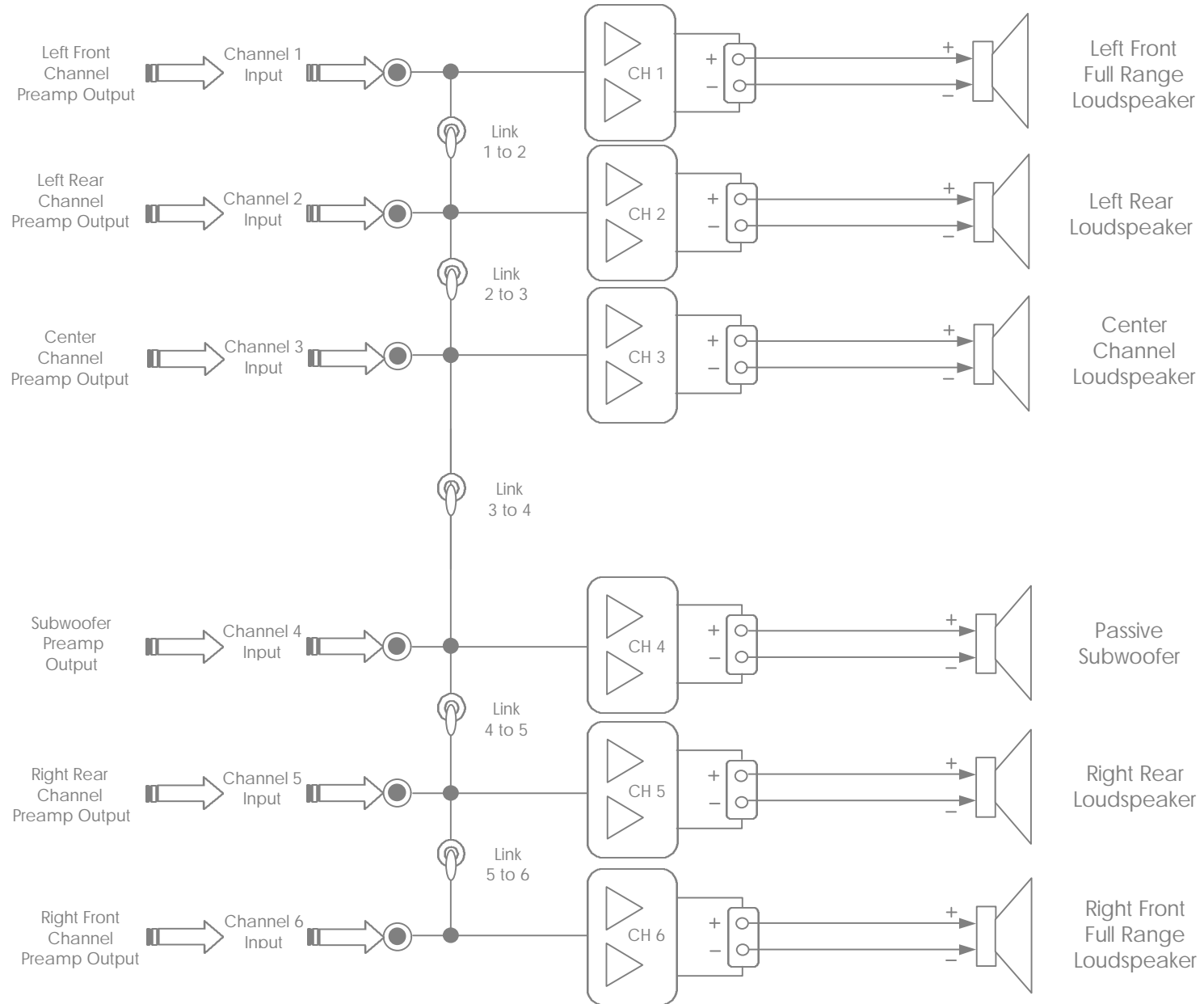

To Configure the Amplifier for Six-Channel Use

- 1 Connect the left front channel interconnect from your pre-amp or source component to the CHANNEL 1 balanced XLR or unbalanced RCA input connector. Select the correct balanced or unbalanced input connector by flipping the Channel 1 BAL/UNBAL switch towards the connector that is being used.
- 2 Connect the right front channel interconnect from your pre-amp or source component to the CHANNEL 6 balanced XLR or unbalanced RCA input connector. Select the correct balanced or unbalanced input connector by flipping the Channel 6 BAL/UNBAL switch towards the connector that is being used.
- 3 Connect the left rear channel interconnect from your pre-amp or source component to the CHANNEL 2 balanced XLR or unbalanced RCA input connector. Select the correct balanced or unbalanced input connector by flipping the Channel 2 BAL/UNBAL switch towards the connector that is being used.
- 4 Connect the right rear channel interconnect from your pre-amp or source component to the CHANNEL 5 balanced XLR or unbalanced RCA input connector. Select the correct balanced or unbalanced input connector by flipping the Channel 5 BAL/UNBAL switch towards the connector that is being used.
- 5 Connect the center channel interconnect from your pre-amp or source component to the CHANNEL 3 balanced XLR or unbalanced RCA input connector. Select the correct balanced or unbalanced input connector by flipping the Channel 3 BAL/UNBAL switch towards the connector that is being used.
- 6 Connect the passive subwoofer channel interconnect from your pre-amp or source component to the CHANNEL 4 balanced XLR or unbalanced RCA input connector. Select the correct balanced or unbalanced input connector by flipping the Channel 4 BAL/UNBAL switch towards the connector that is being used.
- 7 Verify that all of the LINK INPUT switches are in the "OFF" position, or down towards the UNLINK (NORMAL) position.
- 8 Connect your left front loudspeaker cable to the Channel 1 SPEAKER OUTPUT connector.
- 9 Connect your right front loudspeaker cable to the Channel 6 SPEAKER OUTPUT connector.
- 10 Connect your left rear loudspeaker cable to the Channel 2 SPEAKER OUTPUT connector.
- 11 Connect your right rear loudspeaker cable to the Channel 5 SPEAKER OUTPUT connector.
- 12 Connect your center channel loudspeaker cable to the Channel 3 SPEAKER OUTPUT connector.
- 13 Connect your passive subwoofer loudspeaker cable to the Channel 4 SPEAKER OUTPUT connector.

The signal connections are now complete. Please recheck your connections before operating the amplifier.

MC-6 Multi-Channel Power Amplifier Specifications

Power Output per Channel:

Continuous RMS watts	<u>Monoblock:</u>	<u>Two-Channel:</u>	<u>Six-Channel:</u>
@8 ohms	330 watts	250 watts	150 watts
@4 ohms	600 watts	400 watts	250 watts

Power Bandwidth: 0.1 Hz to 160 kHz, -3 dB

Slew Rate: 25 volts/microsecond

THD + Noise: Less than 0.01% at Rated Power

Damping Factor: >60, Channels 1 and 6
>40, Channels 2 through 5

Gain (1 watt, 8 ohms): 26 dB, 141 mV

Input Impedance: 36k ohms per Channel

Common Mode Rejection Ratio: >75 dB, 20 – 20 kHz

Absolute Phase: Phase-Inverted

Output Current:

60 amps peak, Channels 1 and 6
30 amps peak, Channels 2 – 5
Linked channels are cumulative

Power Consumption:

40 Watts Standby, 200 Watts Idle,
1200 Watts Maximum

Inputs:

User Selectable,
6 x Balanced XLR
6 x Unbalanced RCA

Outputs:

Six Pairs Five-Way Binding Posts

Amplifier Dimensions:

17.5" W x 22" D x 11.4" H
44.5 cm W x 56 cm D x 28.5 cm H

Amplifier Weight:

124 lbs.
56 kg

Shipping Dimensions:

24" W x 22" D x 13" H
61cm W x 56cm D x 33cm H

Shipping Weight:

164 lbs.
75 kg

Basic Troubleshooting

A summary of fault conditions and their causes and remedies are listed below.

The MC-6 Multi-Channel Power Amplifier can produce high power levels that, without well-designed protection circuitry, could damage loudspeakers. Therefore, most fault conditions will result in the MC-6 reverting to Standby Mode.

Condition:	Cause:	Remedy:
Front panel STANDBY/POWER BUTTON does not illuminate after pressing, amplifier operates normally:	Light bulb defective.	Remove STANDBY/POWER BUTTON from front panel and replace bulb located under button. Use replacement bulb kit and instructions supplied by your dealer.
Front panel STANDBY/POWER BUTTON lamp does not illuminate after pressing and amplifier does not operate normally.	Incorrect power connections or circuit breaker positions on rear panel of amplifier.	Review Installation/Rear Panel Power Connections section of Owner's Manual.
	Abnormal Operation of the MC-6 internal circuitry.	Contact your dealer immediately.
Front panel STANDBY/POWER BUTTON reverts to Standby Mode during listening but can be returned to normal operation:	Excessive sub-sonic or DC signals produced by source components.	Repair or replace source component. Identify and correct abnormal conditions such as low frequency rumble and/or acoustic feedback caused by phono playback (if applicable).
	Severe clipping of amplifier circuitry.	Reduce volume slightly or use higher efficiency loudspeakers.
AC MAINS CIRCUIT BREAKER switches OFF or will not remain ON:	AC mains voltage too high for amplifier.	Consult your dealer immediately to have the amplifier reconfigured for the proper AC mains voltage.
	Abnormal operation of amplifier internal circuitry.	Contact your dealer immediately.
50/60 Hz buzz noise in loudspeakers:	Ground loop condition created between components in system.	Use balanced system configuration if possible.
		Inspect interconnect cables for poor connection or termination.

Additional Information

If you have any additional questions regarding the installation or operation of the MC-6 Multi-Channel Power Amplifier, please contact your authorized Jeff Rowland Design Group dealer or check the Jeff Rowland Design Group web site at <http://www.jeffrowland.com>.

Post Office Box 7231 Colorado Springs, Colorado 80933 USA